

Generic AC or DC connection diagram - power on/off by power supply.

⚠ Caution: Never connect AC + DC power supplies as this would damage the module.
Cut, insulate and tie the wires that are not used.

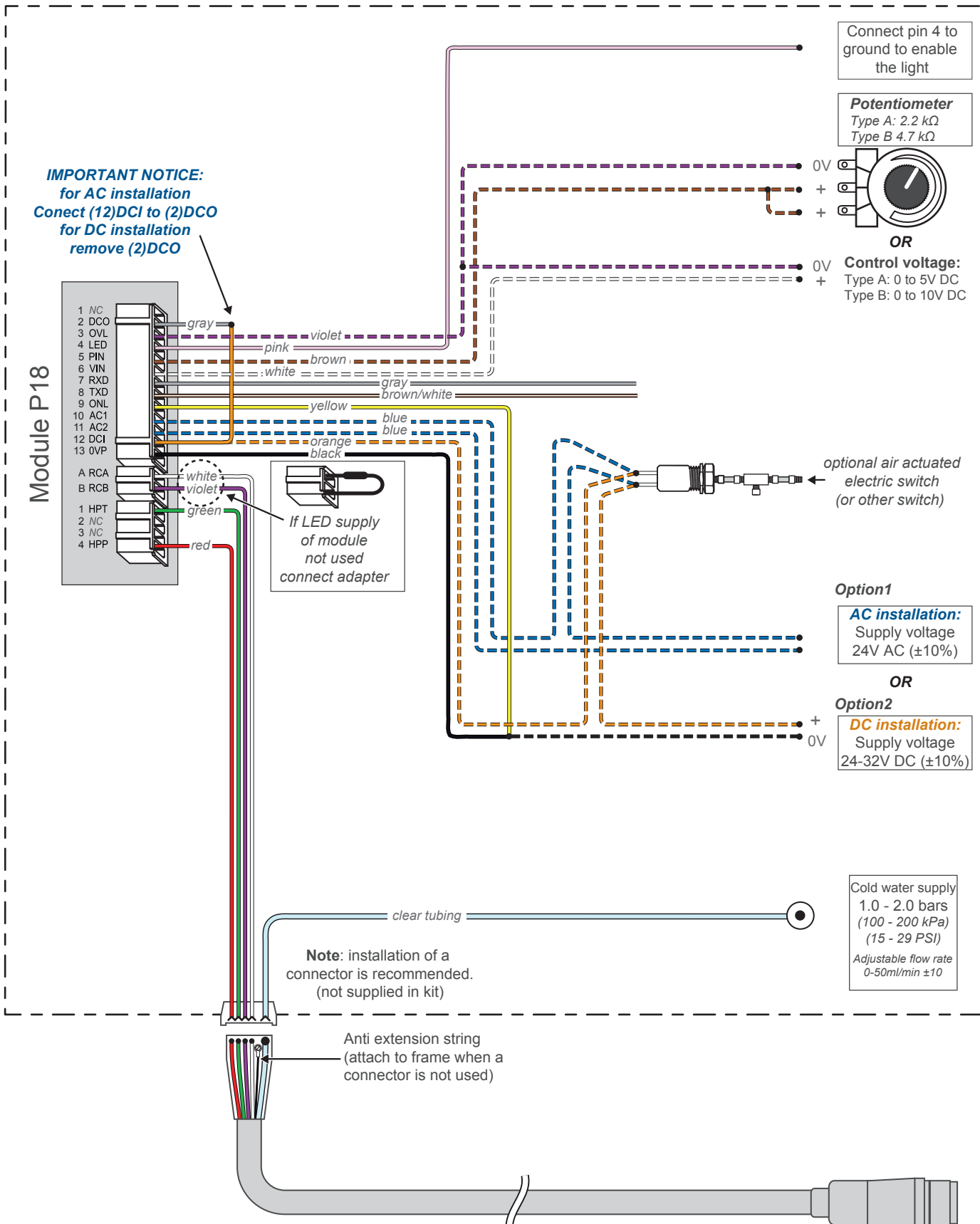

© Copyright EMS SA ed. 2011/12

Generic AC or DC connection diagram - remote power on/off - Module P18 Type B only.

Caution: Never connect AC + DC power supplies as this would damage the module.
Cut, insulate and tie the wires that are not used.

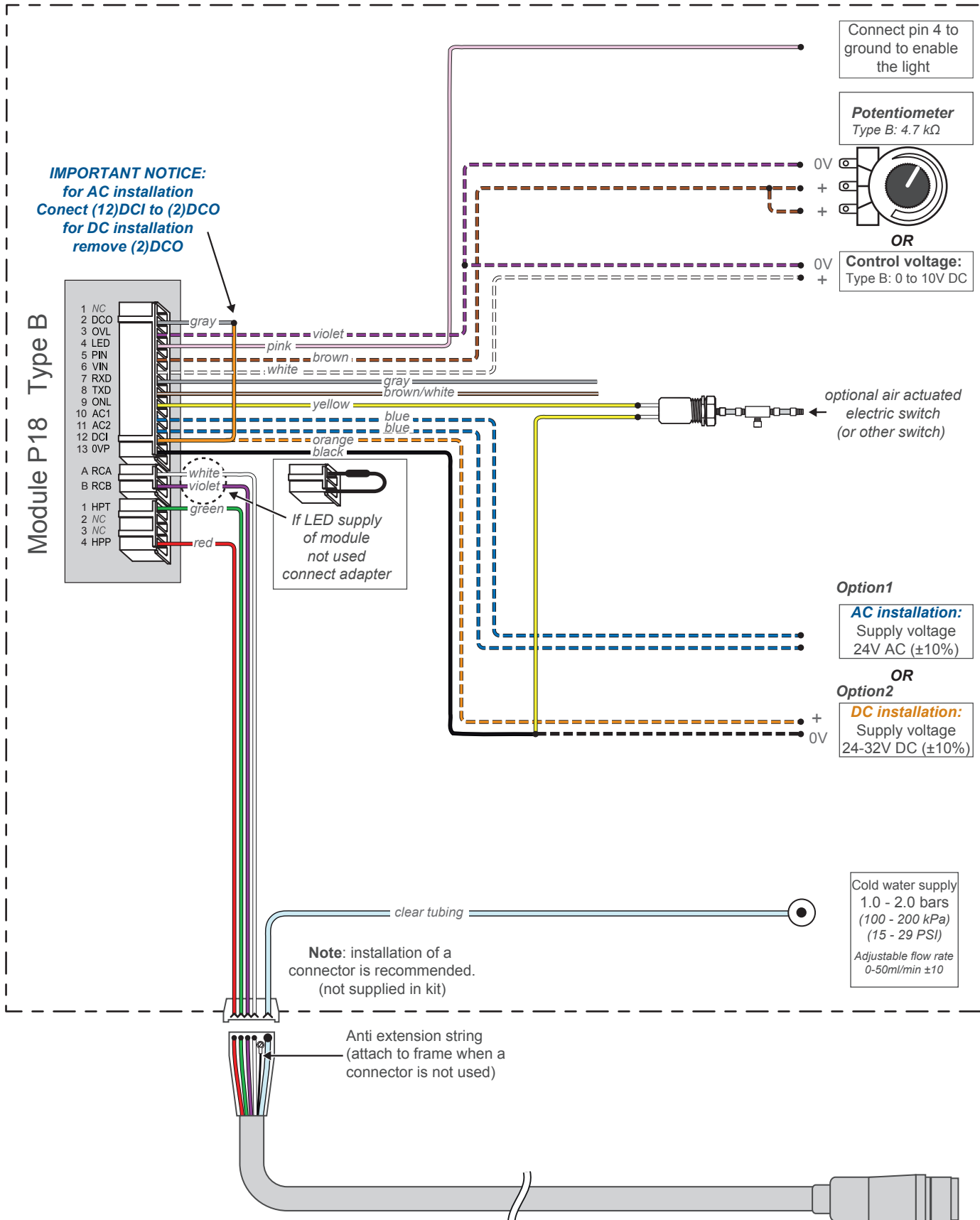

© Copyright EMS SA FB-519 ed. 2011/12

EMS Electro Medical Systems SA
Ch. de la Vuarpillière 31
1260 Nyon / Switzerland
Tel. +41 22 99 44 700
Fax +41 22 99 44 701
e-mail: welcome@ems-ch.com
www.ems-swissquality.ch

EMS world wide offices
EMS Canada Inc.
5524 St. Patrick St., Suite 312
Montreal, QC H4E 1A8
Tel. +1 514 736 5066
Fax. +1 514 736 5065
e-mail: info@ems-canada.ca

EMS France Sarl / 23. Av. Louis Bréguet
Immeuble Santos Dumont, Bât. D,
F-78140 Velizy Villacoublay
Tel. +33 1 34 58 03 80
Fax +33 1 34 58 03 90
e-mail: info@ems-france.fr

EMS GmbH
Schatzbogen 86
D-81829 München
Tel. +49 89 42 71 610
Fax +49 89 42 71 6100
e-mail: info@ems-ch.de

EMS Italia S.p.a.
Via Faravelli 5
I-20149 Milano
Tel. +39 02 3453 8111
Fax +39 02 3453 2778
e-mail: dental@ems-italia.it

EMS España SL
Bernardino Obregón 14 bis,
E-28012 Madrid
Tel. +34 91 528 99 89
Fax +34 91 539 34 89
e-mail: ems-es@arrakis.es

EMS Corporation
11086 Greenville Ave. #120
Dallas TX-75243, USA
Tel. +1 972 690 83 82
Fax +1 972 690 89 81
e-mail: emsusa@emsdent.com

EMS
ELECTRO MEDICAL SYSTEMS

Generic AC or DC connection diagram - remote power on/off - Module P18 Type A only.

Caution: Never connect AC + DC power supplies as this would damage the module.
Cut, insulate and tie the wires that are not used.

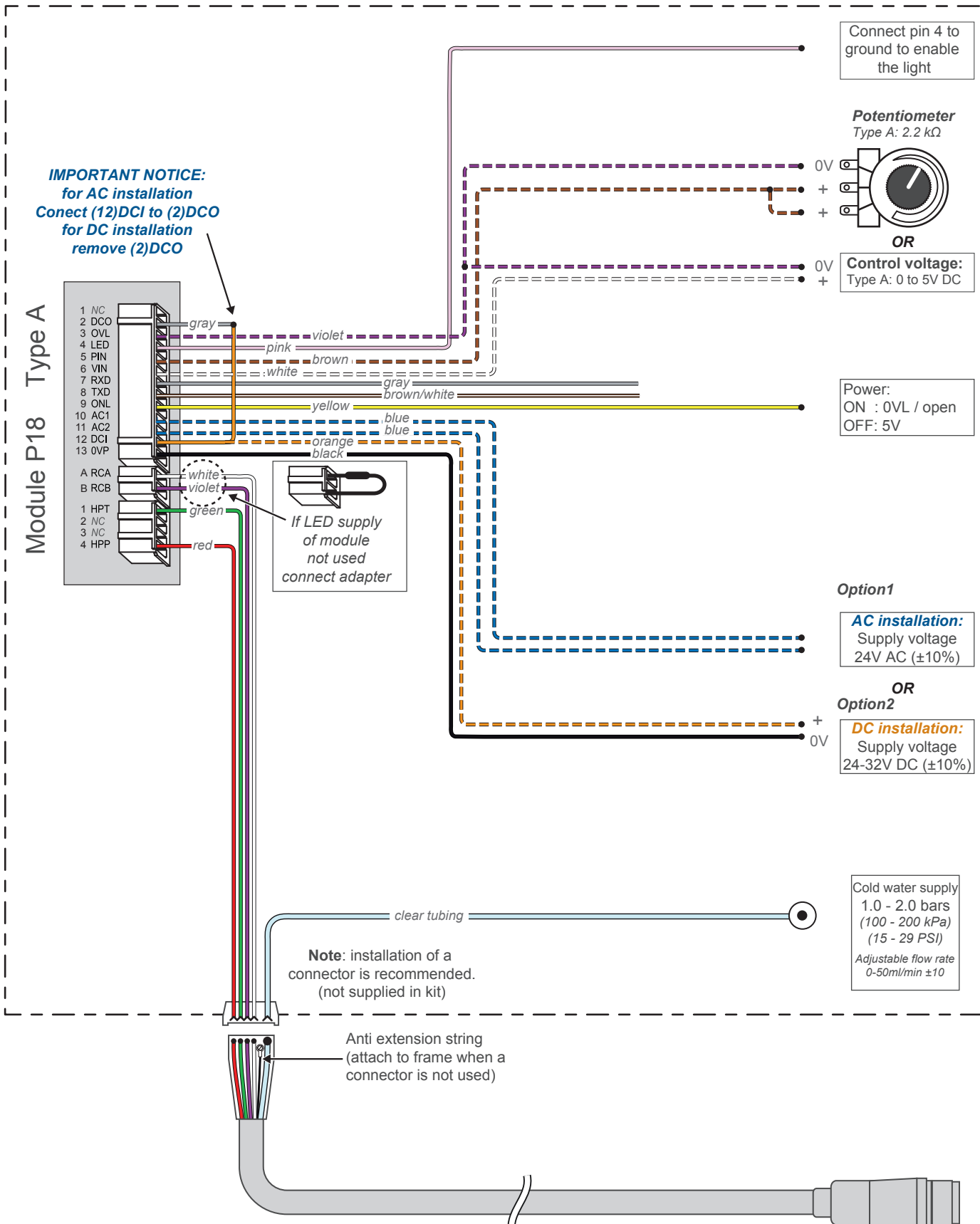

© Copyright EMS SA FB-519 ed. 2011/12

